

DATA SHEET

# SMV1247-SMV1255 Series: Hyperabrupt Junction Tuning Varactors

## Applications

- Low tuning voltage VCOs
- High-volume commercial systems

## Features

- High capacitance ratio:  $C_{0.3V}/C_{4.7V} = 12$  typical
- Packages rated MSL1, 260 °C per JEDEC J-STD-020

**NEW**

Skyworks offers lead (Pb)-free, RoHS (Restriction of Hazardous Substances) compliant packaging.



## Description

The SMV1247-SMV1255 group of silicon hyperabrupt junction varactor diodes is designed for use in Voltage Controlled Oscillators (VCOs) with a low tuning voltage operation. This group of varactors is characterized for capacitance and resistance over temperature.

Table 1 describes the various packages and markings of the SMV1247 to SMV1255 varactors.

**Table 1. Packaging and Marking**

Single	Single	Single	Common Anode	Common Cathode	Common Cathode
SC-79	SOD-323	SOT-23	SOT-23	SOT-23	SC-70
					◆ SMV1247-074 Marking: BF3
◆ SMV1247-079LF Marking: Cathode	SMV1247-011LF Marking: GF				◆ SMV1247-074LF Marking: GF3
SMV1248-079LF Marking: Cathode		SMV1248-001 Marking: BG1			SMV1248-074 Marking: GG3
		SMV1248-001LF Marking: GG1			SMV1248-074LF Marking: GG3
		SMV1249-001 Marking: AF1	SMV1249-003 Marking: AF9	SMV1249-004 Marking: AF3	SMV1249-074 Marking: AF3
◆ SMV1249-079LF Marking: Cathode	SMV1249-011LF Marking: EF	SMV1249-001LF Marking: EF1	SMV1249-003LF Marking: EF9	SMV1249-004LF Marking: EF3	SMV1249-074LF Marking: EF3
				SMV1251-004 Marking: AH3	SMV1251-074 Marking: AH3
SMV1251-079LF Marking: Cathode	SMV1251-011LF Marking: EH	SMV1251-001LF Marking: EH		SMV1251-004LF Marking: EH3	SMV1251-074LF Marking: EH3
				SMV1253-004 Marking: AJ3	
SMV1253-079LF Marking: Cathode				SMV1253-004LF Marking: EJ3	
		SMV1255-001 Marking: AK1		SMV1255-004 Marking: AK3	
◆ SMV1255-079LF Marking: Cathode	SMV1255-011LF Marking: EK	SMV1255-001LF Marking: EK1		SMV1255-004LF Marking: EK3	
Ls = 0.7 nH	Ls = 1.5 nH	Ls = 1.5 nH		Ls = 1.5 nH	



LF denotes lead (Pb)-free, RoHS-compliant packaging option as an alternative to the standard Skyworks tin/lead (Sn/Pb) packaging.



**Innovation to Go™**

Select Linear Products (indicated by ◆) now available for purchase online.

## Electrical and Mechanical Specifications

The absolute maximum ratings of the SMV1247-SMV1255 group of varactors are provided in Table 2. Electrical specifications are provided in Table 3. Typical capacitance values are listed in Table 4. Typical performance characteristics of the SMV1247-SMV1255 varactors are illustrated in Figures 1 through 4.

The SPICE model for the SMV1247-SMV1255 varactors is shown in Figure 5 and the associated model parameters are provided in Table 5. Package dimensions are shown in Figures 6 to 12 (even numbers), and tape and reel dimensions are provided in Figures 7 to 13 (odd numbers).

## Package and Handling Information

Instructions on the shipping container label regarding exposure to moisture after the container seal is broken must be followed. Otherwise, problems related to moisture absorption may occur when the part is subjected to high temperature during solder assembly.

The SMV1247-SMV1255 group of varactors are rated to Moisture Sensitivity Level 1 (MSL1) at 260 °C. They can be used for lead or lead-free soldering. For additional information, refer to the Skyworks Application Note, *Solder Reflow Information*, document number 200164

Care must be taken when attaching this product, whether it is done manually or in a production solder reflow environment. Production quantities of this product are shipped in a standard tape and reel format. For packaging details, refer to the Skyworks Application Note *Discrete Devices and IC Switch/Attenuators Tape and Reel Package Orientation*, document number 200083.

**Table 2. SMV1247-SMV1255 Absolute Maximum Ratings**

Parameter	Symbol	Minimum	Typical	Maximum	Units
Reverse voltage	$V_R$			15	V
Forward current	$I_F$			20	mA
Power dissipation	$P_{DIS}$			250	mW
Operating temperature	$T_{OP}$	-55		+125	°C
Storage temperature	$T_{STG}$	-55		+150	°C

**Note:** Exposure to maximum rating conditions for extended periods may reduce device reliability. There is no damage to device with only one parameter set at the limit and all other parameters set at or below their nominal value. Exceeding any of the limits listed here may result in permanent damage to the device.

**CAUTION:** Although this device is designed to be as robust as possible, Electrostatic Discharge (ESD) can damage this device. This device must be protected at all times from ESD. Static charges may easily produce potentials of several kilovolts on the human body or equipment, which can discharge without detection. Industry-standard ESD precautions should be used at all times. The SMV1247-SMV1255 series varactors are Class 0 Human Body Model (HBM) ESD devices.

**Table 3. SMV1247-SMV1255 Electrical Specifications (Note 1)**  
( $T_{OP} = 25\text{ °C}$ , Unless Otherwise Noted)

Part Number	$C_T$ @ 0.3 V (pF)		$C_T$ @ 4.7 V (pF)		$C_T$ @ 1 V (pF)	$C_T$ @ 3 V (pF)	$\frac{C_T @ 0.3 V}{C_T @ 4.7 V}$ (Ratio)		$\frac{C_T @ 1 V}{C_T @ 3 V}$ (Ratio)	$R_s @ 3 V,$ 500 MHz ( $\Omega$ )	$Q @ 3 V,$ 50 MHz
	Min.	Typical	Typical	Max.	Typical	Typical	Min.	Typical	Typical	Max.	Typical
SMV1247	6.5	7	0.7	0.78	4.4	0.95	9.5	10.0	4.6	6.0	1500
SMV1248	15.0	17	1.5	1.70	12.3	2.60	10.8	12.0	4.7	3.3	700
SMV1249	28.0	31	2.6	2.80	18.2	3.40	11.0	12.1	5.3	2.2	600
SMV1251	38.0	42	3.4	3.80	28.1	5.80	11.0	12.2	4.8	1.6	400
SMV1253	48.0	53	4.3	4.80	37.0	7.80	11.0	12.3	4.7	1.4	350
SMV1255	58.0	64	5.2	5.80	43.3	8.50	11.0	12.3	5.1	1.3	350

**Note 1:** Performance is guaranteed only under the conditions listed in this Table and is not guaranteed over the full operating or storage temperature ranges. Operation at elevated temperatures may reduce reliability of the device.

Reverse voltage  $V_R$  ( $I_R = 10\ \mu A$ ) = 15 V minimum  
Reverse current  $I_R$  ( $V_R = 12\ V$ ) = 20 nA maximum

**Table 4. Capacitance vs Reverse Voltage**

V <sub>R</sub> (V)	C <sub>T</sub> (pF)					
	SMV1247	SMV1248	SMV1249	SMV1251	SMV1253	SMV1255
0	8.86	22.62	37.35	53.65	69.32	81.21
0.5	6.17	16.32	25.88	38.23	50.23	58.28
1.0	4.37	12.33	18.18	28.09	37.07	43.27
1.5	2.96	9.12	12.08	20.13	27.57	31.49
2.0	1.88	6.27	7.27	13.55	19.37	21.50
2.5	1.22	3.93	4.44	8.60	12.39	13.40
3.0	0.95	2.57	3.40	5.78	7.77	8.51
3.5	0.83	1.95	2.96	4.57	5.77	6.51
4.0	0.77	1.71	2.72	3.95	4.86	5.58
4.5	0.73	1.59	2.51	3.58	4.34	5.07
5.0	0.70	1.49	2.38	3.33	4.01	4.76
5.5	0.68	1.44	2.30	3.16	3.78	4.58
6.0	0.67	1.40	2.24	3.03	3.62	4.46
6.5	0.66	1.36	2.19	2.94	3.50	4.39
7.0	0.65	1.33	2.14	2.88	3.41	4.33
7.5	0.64	1.31	2.09	2.83	3.34	4.29
8.0	0.64	1.30	2.03	2.79	3.28	4.26

**Typical Performance Characteristics**

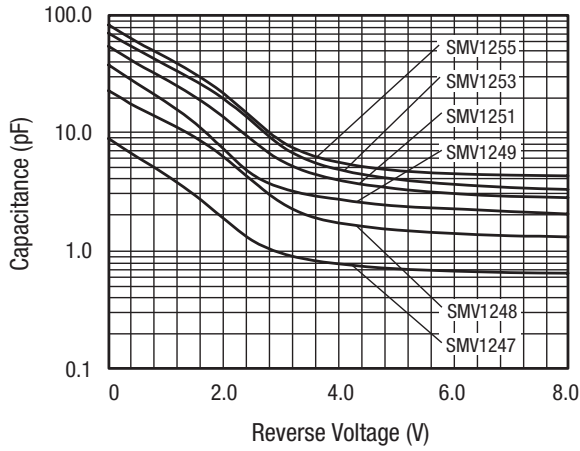

**Figure 1. Capacitance vs Reverse Voltage**

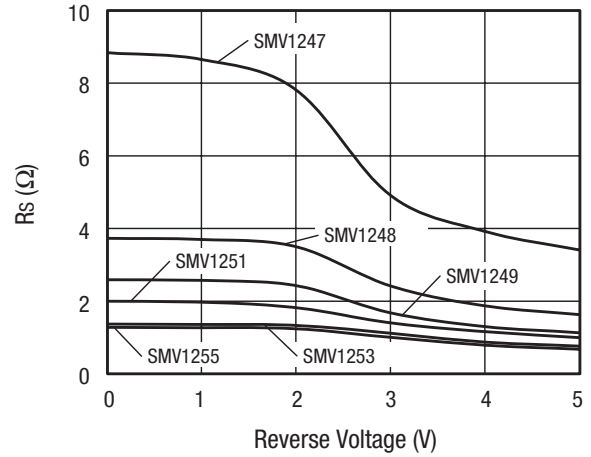

**Figure 2. Series Resistance vs Reverse Voltage @ 500 MHz**

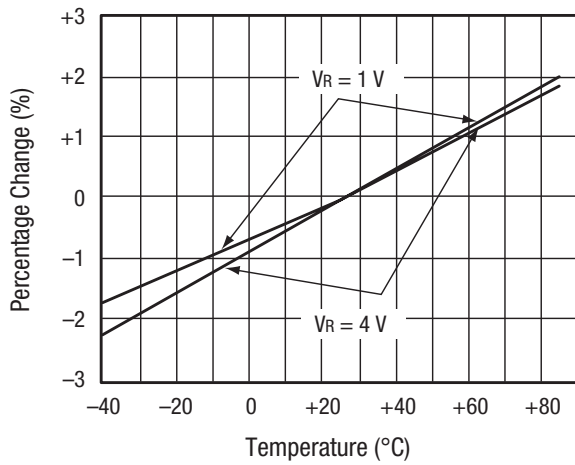

**Figure 3. Relative Capacitance Change vs Temperature**

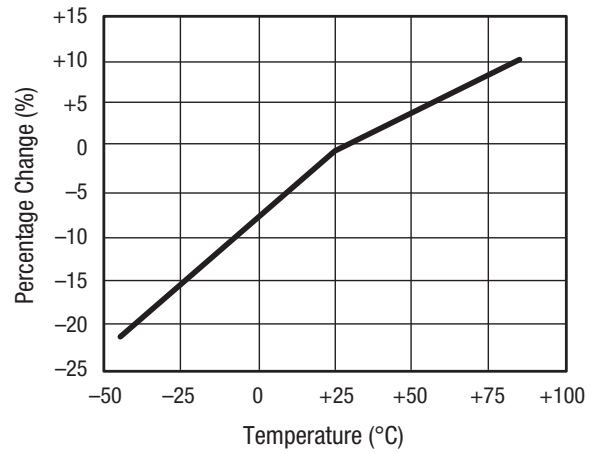

**Figure 4. Relative Series Resistance Change vs Temperature @ 500 MHz**

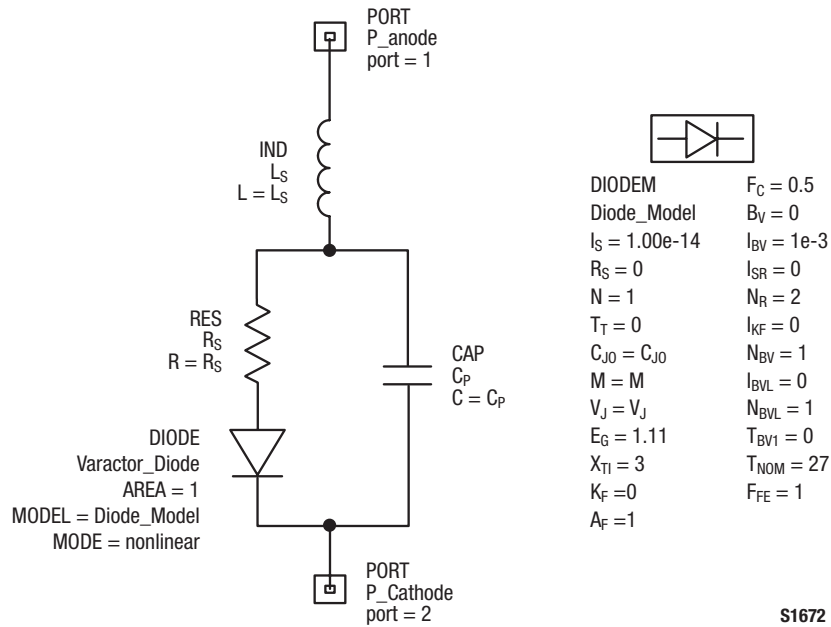

Figure 5. SPICE Model

Table 5. SPICE Model Parameters

Part Number	Cj0 (pF)	Vj (V)	M	Cp (pF)	Rs (Ω)
SMV1247	9.22	13	10.5	0	4.9
SMV1248	21.54	13	10.5	0	2.4
SMV1249	39.00	17	14.0	0	1.7
SMV1251	60.00	17	14	0	1.4
SMV1253	70.00	17	14	0	1.1
SMV1255	82.00	17	13	0	1.0

Model was designed to fit measured data in the range of up to 4 V.

For package inductance (Ls), refer to Table 1.

For more details, refer to the Skyworks Application Note, *Varactor SPICE Model for Approved RF VCO Applications*, document number 200315.

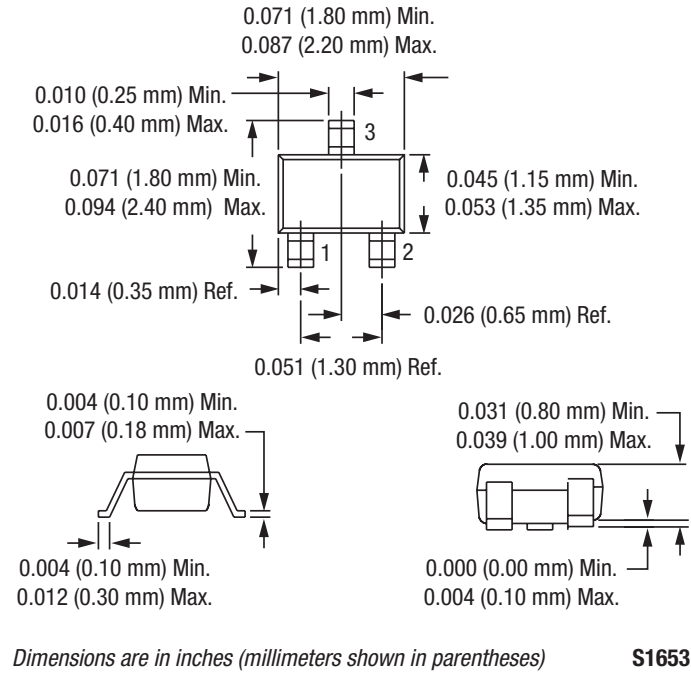

Figure 6. SC-70 Package Dimensions

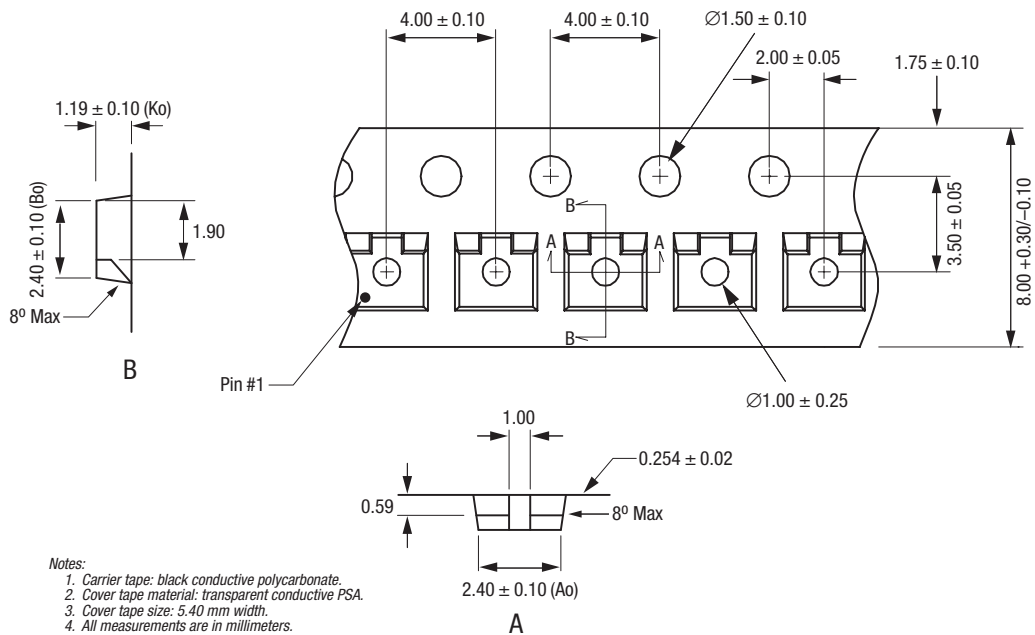
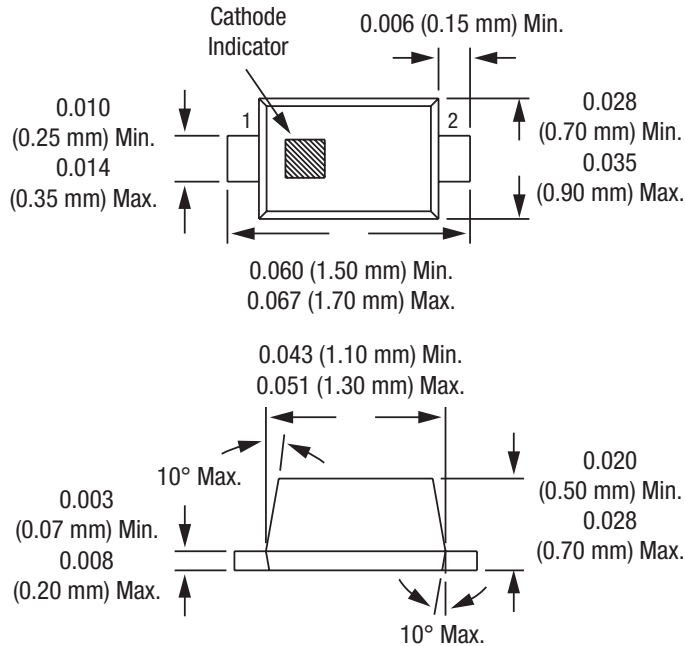
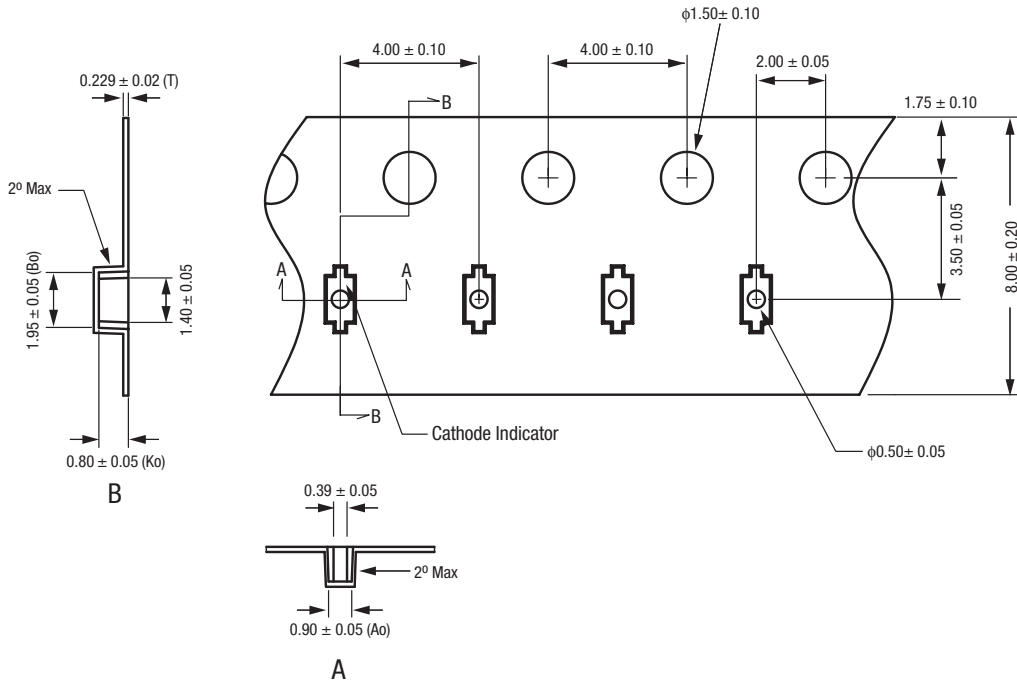

Figure 7. SC-70 Tape and Reel Dimensions



Dimensions are in inches (millimeters shown in parentheses) S1652

Figure 8 SC-79 Package Dimensions



- Notes:
1. Carrier tape: black conductive polycarbonate or polystyrene.
  2. Cover tape material: transparent conductive PSA.
  3. Cover tape size: 5.4 mm width.
  4. All measurements are in millimeters.

S1673

Figure 9. SC-79 Tape and Reel Dimensions



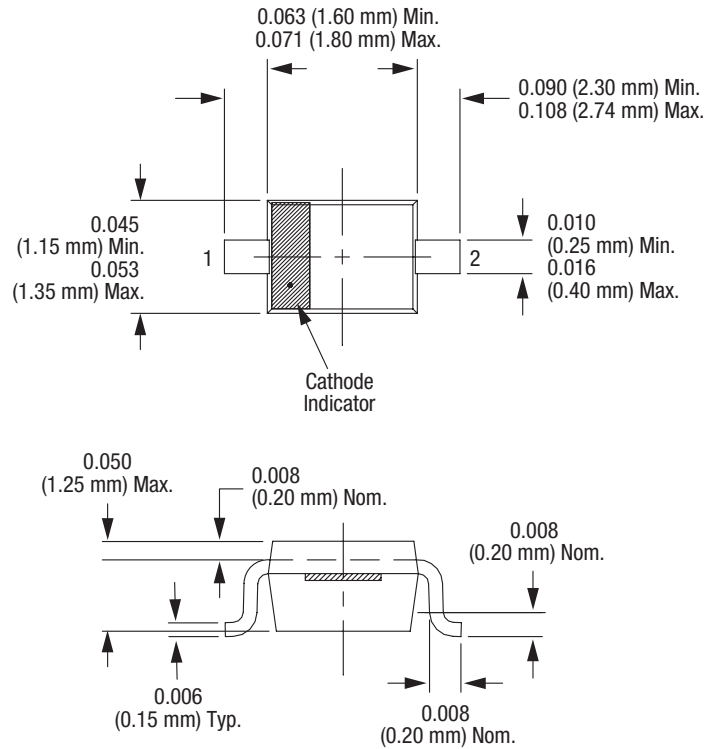

Dimensions are in inches (millimeters shown in parentheses)

S1619

**Figure 10. SOD-323 Package Dimensions**

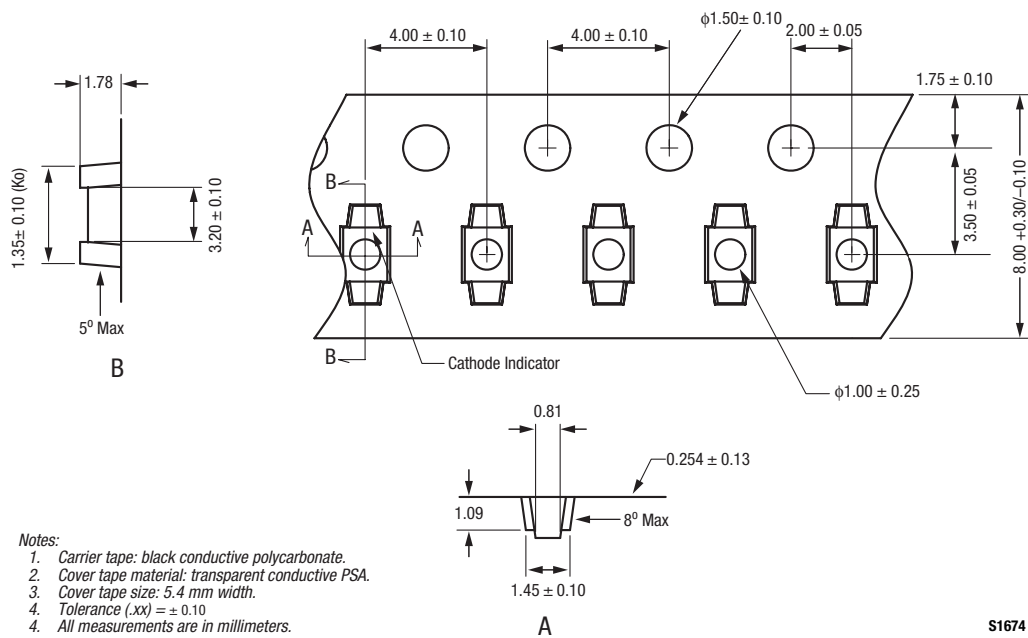

- Notes:
1. Carrier tape: black conductive polycarbonate.
  2. Cover tape material: transparent conductive PSA.
  3. Cover tape size: 5.4 mm width.
  4. Tolerance (.xx) = ± 0.10
  4. All measurements are in millimeters.

S1674

**Figure 11. SOD-323 Tape and Reel Dimensions**

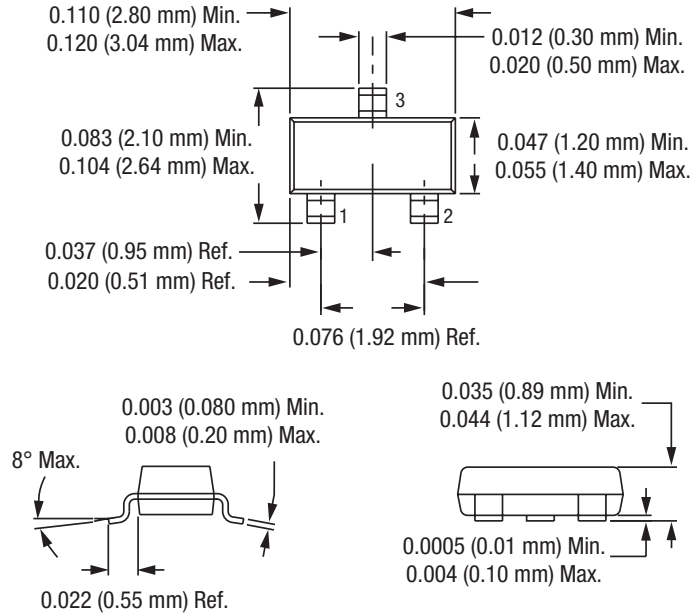

Dimensions are in inches (millimeters shown in parentheses)

S1389

Figure 12. SOT-23 Package Dimensions

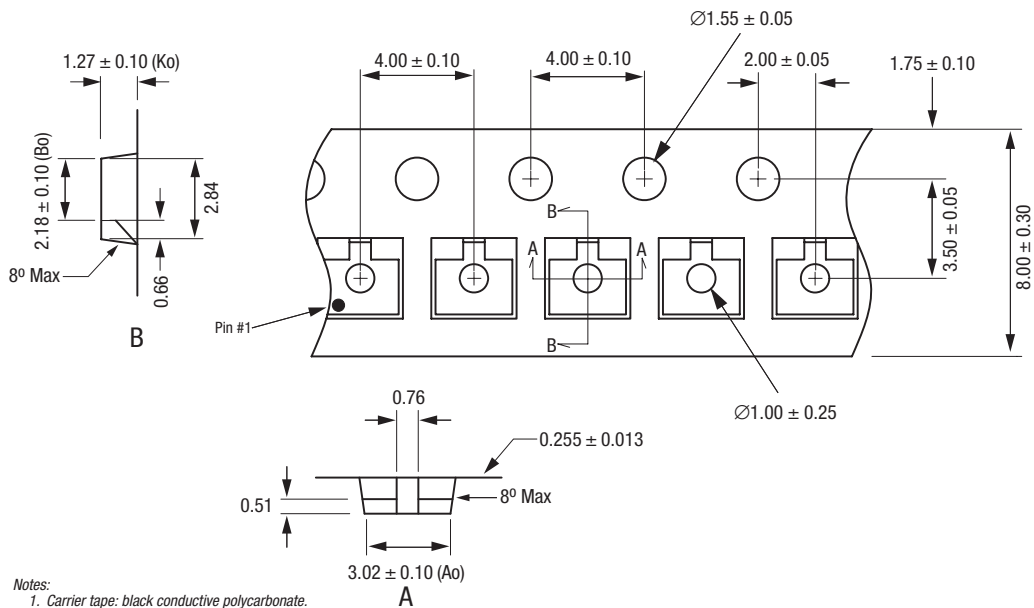

Notes:

1. Carrier tape: black conductive polycarbonate.
2. Cover tape material: transparent conductive PSA.
3. Cover tape size: 5.40 mm width.
4. Tolerance ±0.10 mm.
5. All measurements are in millimeters.

S1684

Figure 13. SOT-23 Tape and Reel Dimensions

Copyright © 2002-2007, 2009 Skyworks Solutions, Inc. All Rights Reserved.

Information in this document is provided in connection with Skyworks Solutions, Inc. ("Skyworks") products or services. These materials, including the information contained herein, are provided by Skyworks as a service to its customers and may be used for informational purposes only by the customer. Skyworks assumes no responsibility for errors or omissions in these materials or the information contained herein. Skyworks may change its documentation, products, services, specifications or product descriptions at any time, without notice. Skyworks makes no commitment to update the materials or information and shall have no responsibility whatsoever for conflicts, incompatibilities, or other difficulties arising from any future changes.

No license, whether express, implied, by estoppel or otherwise, is granted to any intellectual property rights by this document. Skyworks assumes no liability for any materials, products or information provided hereunder, including the sale, distribution, reproduction or use of Skyworks products, information or materials, except as may be provided in Skyworks Terms and Conditions of Sale.

THE MATERIALS, PRODUCTS AND INFORMATION ARE PROVIDED "AS IS" WITHOUT WARRANTY OF ANY KIND, WHETHER EXPRESS, IMPLIED, STATUTORY, OR OTHERWISE, INCLUDING FITNESS FOR A PARTICULAR PURPOSE OR USE, MERCHANTABILITY, PERFORMANCE, QUALITY OR NON-INFRINGEMENT OF ANY INTELLECTUAL PROPERTY RIGHT; ALL SUCH WARRANTIES ARE HEREBY EXPRESSLY DISCLAIMED. SKYWORKS DOES NOT WARRANT THE ACCURACY OR COMPLETENESS OF THE INFORMATION, TEXT, GRAPHICS OR OTHER ITEMS CONTAINED WITHIN THESE MATERIALS. SKYWORKS SHALL NOT BE LIABLE FOR ANY DAMAGES, INCLUDING BUT NOT LIMITED TO ANY SPECIAL, INDIRECT, INCIDENTAL, STATUTORY, OR CONSEQUENTIAL DAMAGES, INCLUDING WITHOUT LIMITATION, LOST REVENUES OR LOST PROFITS THAT MAY RESULT FROM THE USE OF THE MATERIALS OR INFORMATION, WHETHER OR NOT THE RECIPIENT OF MATERIALS HAS BEEN ADVISED OF THE POSSIBILITY OF SUCH DAMAGE.

Skyworks products are not intended for use in medical, lifesaving or life-sustaining applications, or other equipment in which the failure of the Skyworks products could lead to personal injury, death, physical or environmental damage. Skyworks customers using or selling Skyworks products for use in such applications do so at their own risk and agree to fully indemnify Skyworks for any damages resulting from such improper use or sale.

Customers are responsible for their products and applications using Skyworks products, which may deviate from published specifications as a result of design defects, errors, or operation of products outside of published parameters or design specifications. Customers should include design and operating safeguards to minimize these and other risks. Skyworks assumes no liability for applications assistance, customer product design, or damage to any equipment resulting from the use of Skyworks products outside of stated published specifications or parameters.

Skyworks, the Skyworks symbol, and "Breakthrough Simplicity" are trademarks or registered trademarks of Skyworks Solutions, Inc., in the United States and other countries. Third-party brands and names are for identification purposes only, and are the property of their respective owners. Additional information, including relevant terms and conditions, posted at [www.skyworksinc.com](http://www.skyworksinc.com), are incorporated by reference.